

OPERATION AND MAINTENANCE

MODEL 1053 DOME/BIAS LOAD REGULATOR

The model 1053 is a dome loading regulator. Additionally an adjustable spring bias is provided such that the regulator set point can be varied from 0 to 400 PSI above the dome loading pressure. The regulator is self venting. It uses the same reliable valve cartridge used on the 415 series spring loaded regulators. This regulator is about 4 times as accurate as the 415 series but requires a separate source of control pressure to load the dome. AS WITH ANY REGULATOR, A RELIEF VALVE SET SLIGHTLY ABOVE THE MAXIMUM DESIRED CONTROL PRESSURE SHOULD BE INSTALLED ON THE OUTLET SIDE.

SPECIFICATIONS

- Maximum pressure

inlet	6000	PSI	(40
MPa)			
outlet	4000	PSI	
dome	4000	PSI	
- Ports

inlet	1/4" FNPT
outlet	1/4" FNPT
dome control	1/4" FNPT
guage ports	1/4" FNPT
- Flow coefficient 0.05 (.07" orifice)
- Rise of outlet pressure with drop of inlet pressure 8 PSI/1000 PSI
- Materials - body and cap - aluminum

internals -	brass, stainless,
seals, -	Viton, KEL-F
- Size 2.25" dia x 5.5" lg

INSTALLATION

Use a suitable pipe thread sealant such as teflon tape on pipe threads. Use three or more wraps of tape. Avoid over-torquing fittings. Normal torque applied with a 6 or 8 inch wrench is sufficient. The inlet, outlet and guage ports are arranged 60 degrees apart on the lower body. Viewing from the dome end of the regulator and with the two guage ports on top, the inlet port is on the left and outlet on the right. Flow direction is also noted by the flow arrow at the bottom of the regulator. The dome loading port is on the side of the upper hexagon shaped adaptor. This adaptor can be rotated up to 2/3 turn from the fully tighten position to orient the port as desired. However, turning this adaptor changes the spring bias setting so the bias should be set after orienting the port.

The brass screw at the top of the regulator sets the spring bias. To set bias pressure, attach a guage to the outlet. With pressure at the inlet and the dome

port open to atmosphere set the adjusting screw to the desired pressure. Avoid backing this screw out beyond the point where spring pressure is relieved. O ring damage could result.

If the dome pressurizing fluid is either corrosive or dirty it is recommended the dome be filled with an inert liquid such as silicone oil. Pressure can then be transferred to the dome via a flexible diaphragm that separates the process fluid from the regulator.

An optional mounting ring (part number 657) is available. The ring clamps on the larger body diameter and has two 1/4" panel mounting screws 180 degree apart separated by 2.8".

The regulator is NOT supplied oxygen clean and should NOT be used for oxygen service. Consult factory for details.

MAINTANENCE & REPAIR

CAUTION As with any regulator or valve, particulates or moisture can plug or freeze the internal filter or valve seat. This can occur when up-stream dryers are not changed or remain unused for long periods allowing corosion materials to accumulate. In critical applications where it is important not to lose flow, a larger particulate filter should be used upstream. Also an orifice such as the Aqua model 796 should be used downstream. This reduces the tendency to freeze when moisture is present. Consult factory for details. The user should establish time intervals for changing the valve cartridge, filter and upstream dryers based on experience and service conditions. No representation is made herein as to time intervals as each use is unique. Back-up systems should be used in very critical applications since field maintenance is hard to insure. If repairs are required, the regulator should only be disassembled and assembled by a qualified person in a clean environment by following the drawings, notes, and parts lists herein. However, it is recommended the unit be returned to the factory for repairs if time allows. In-field disassembly of the poppet cartridge (assembly 832) is not recommended. Spare poppet cartridge assemblies should be kept if in-field servicing is required.

If leakage occurs through the regulator or out the regulator vent, allow the inlet and outlet pressure to equalize by shutting off the inlet. If leakage continues after the inlet and outlet equalize the vent seat 4 or piston seal 10 is leaking. Replace them. If leakage stops when the inlet and outlet pressure equalize the poppet cartridge item 1 is leaking. Replace this.

AQUA ENVIRONMENT CO., INC.

3100 Kerner Blvd., Unit N, San Rafael, CA 94901, (415) 453 8157

ASSEMBLY & DISASSEMBLY - MODEL 1053 REGULATOR

ITEM	QTY	PART NO.	DESCRIPTION
1	1	832	valve cartridge
assy			
2	1	407	body
3	1	746	vent seat
4	1	1082	piston
5	1	1083	piston hsg
6	1	1072	cap
7	1	1081	lower sp guide
8	1	1084	vent tube
9	1	1076	upper sp guide
10	1	1075	guide/seal
11	1	1074	adjusting screw
12	1	1073	adaptor
13	2	1079-13	2-014, 90V seal
14	1	1079-14	2-022, 90 V seal
15	2	1079-15	2-010, 90 V seal
16	2	1079-16	2-006, 90 V seal
17	1	1079-17	spring, 1"x1"xMD
18	2	1079-18	2-028, 90 V seal
19	1	1079-19	2-122, 90 V seal
20	1	657	mount - optional

NOTES

1. Techn ical bulletin - 1080
2. Use Dow silicone grease 111 or equivalent on seals and threads. Fully pack area around item 10.
3. ASSEMBLY
 - a. Clean all parts and insure there are no visible chips or particulates.
 - b. Inspect vent seat 4 under 10X magnification at sealing edge.

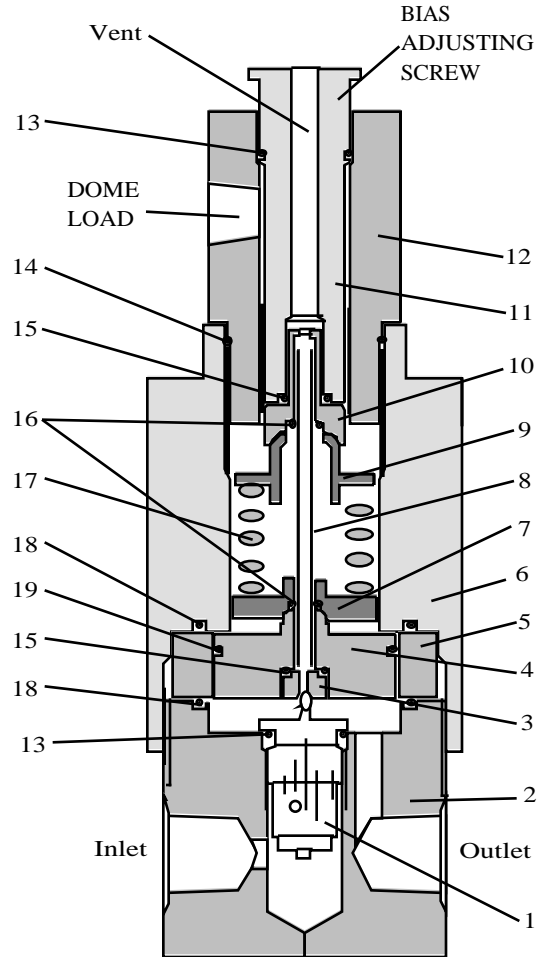

ASSEMBLY 832 Poppet cartridge

ITEM	QTY	PART NO.	DESCRIPTION
1	1	808	retainer nut
2	1	806	poppet housing
3	1	809	sleeve
4	1	807	seat
5	1	741	poppet
6	1	871-6	2-009 O ring
7	1	871-7	2-014 O ring
8	1	871-8	spring
9	1	871-9	filter

NOTES

1. It is recommended that replacement cartridges are stocked for in-field repairs and defective cartridges returned to the factory for service. In emergencies the above parts list can be used for repairs, Extreme cleanliness is required.

