

OPERATION AND MAINTENANCE

MODEL 816-3 (2 WAY), 816-3V (3 WAY), 816-B and 816-B2 AIR OPERATED VALVES

The Model 816 valve is an open or shut valve for air or gas lines up to 6000 PSI. In the normal position with no control pressure applied the valve is shut. Providing control pressure to the upper control port opens the valve. One typical application is to open a cylinder charging line only when a protective door is shut. A one inch thread section is provided permitting a variety of ways to mount the valve.

The 816-3 valve is similar to the older 816-1 valve except the -3 valve uses a larger control piston permitting the use of lower control pressure. The valve, when used with an inexpensive low pressure solenoid, can be used in place of expensive high pressure solenoids. The 816-3V is a 3 way valve. When control pressure is released the downstream pressure is vented off. Similar valves with larger flow coefficients are available in our 1094 series valve.

TECHNICAL SPECIFICATIONS

Maximum pressure, inlet	6000 PSI
differential	6000 PSI
outlet	6000 PSI
Ports, inlet	1/4" MNPT
outlet	1/4" FMPT
	(-B2 has two outlets)
Flow coefficient (Cv)	.05 (.07" orifice)
Materials, body	anodized aluminum
internals	brass & stainless
seals	Viton(TM) & KEL-F
Mod 816-3 actuating pressure	45 PSI at 5000 PSI in and out
	25 PSI at 5000 PSI in and 0 PSI out
Maximum allowable actuating pressure for 816-3	1200 PSI
for 816-3V	1200 PSI

INSTALLATION

Use pipe thread sealant Teflon tape on inlet and outlet threads. Do not over torque. Moderately torque with a 6 or 8 inch wrench. Use ample Teflon tape. TO AVOID PREMATURE FAILURE OF STEM ITEM 4 AN ORIFICE IS REQUIRED AT THE CONTROL AIR PORT. A .047" (#56 DRILL) ORIFICE IS ADEQUATE HOWEVER A .025" ORIFICE INSURES MAXIMUM LIFE. IT IS IMPORTANT TO PLACE THE ORIFICE DIRECTLY ON THE 816 CONTROL PORT TO AVOID EXCESSIVE DEAD VOLUME. The .025" orifice causes about a 1/2 second delay between release of control pressure and venting of high pressure.

Aqua Environment Inc 415 453 8157

The inlet is the male thread and outlet is the female thread at the side of the valve. The one inch thread at the bottom of the valve can be used to mount the valve through a one inch hole in a panel or mounting plate provided by the user. Actuating pressure for the valve can be any non-corrosive gas or liquid at any pressure between the minimum and maximum given above under specifications. Pressure must be relieved for the valve to shut. If an electric solenoid is used, use the three way type to relieve control pressure. The regulator is NOT shipped oxygen clean and should NOT be used for oxygen service as provided. Consult the factory for details on oxygen service.

MAINTENANCE & REPAIR

CAUTION As with any regulator or valve, particulates or moisture can plug or freeze the internal filter or valve seat. This can occur when upstream dryers are not changed or remain unused for long periods allowing corrosion materials to accumulate. In critical applications where it is important not to lose flow, a larger particulate filter should be used upstream. Also an orifice such as the Aqua model 796 should be used downstream. This reduces the tendency to freeze when moisture is present. Consult factory for details. The user should establish time intervals for changing the valve cartridge, filter and upstream dryers based on experience and service conditions. No representation is made herein as to time intervals as each use is unique. Back-up systems should be used in very critical applications since field maintenance is hard to insure. The poppet cartridge 832 is a factory assembled item and should be replaced if required and not disassembled unless absolutely necessary. Spare cartridges are available at a nominal cost and should be kept on hand if rapid repairs are required. Under severe conditions repacking of seals items 12, 14, and 15 with Cristo lub per the drawing may periodically be required. IN ALL CASES THE UNIT CAN BE RETURNED TO THE FACTORY OR DEALER FOR REPAIR UNDER WARRANTY IF APPLICABLE OR AT A NOMINAL CHARGE. Maintenance or repairs should only be done by qualified personnel in a clean environment by following the drawings and parts lists herein.

TOGGLE VALVE MODEL 816-3 & 816-3V, ASSEMBLY & DISASSEMBLY

PARTS LIST

ITEM	QTY	PART NO.	DESCRIPTION
1	1	832	poppet cartridge assy
2	1	811	body
3	1	811-B/B2	body, brass for 816-B or -B2
4	1	812	cap
5	1	812-B	cap, brass for 816-B
6	1	812-B2	cap, brass, 2 out for 816-B2
7	1	815	stem (816-3 only)
8	1	1525	stem, vented (816-3V only)
9	1	1461	cylinder
10	1	1463	piston
11	1	1462	plug
12	1	816-8-3	2-130 viton or buna 70 duro
13	1	816-9	1" x 14, jam nut, plt stl
14	1	816-10	2-018 viton, 90 duro seal
15	1	816-11	2-014 viton, 90 duro seal
16	1	816-12	2-006 viton, 90 duro seal
17	1	816-13	spring (816-3 only)
18	1	816-3-14	2-124 viton 90
19	1	816-3-15	2-122 viton 75
20	1	816-16	REPAIR KIT for 816-3 incl 1,4,10,11,12,13, 14,15
21	1	816-3V-16	REPAIR KIT FOR 816-3V inc 1,4,10,11,12,14,15,17,18
22	1	726-1	vent seat (816-3V only)
23	1	816-18	2-009 viton 90 seal (816-3V only)

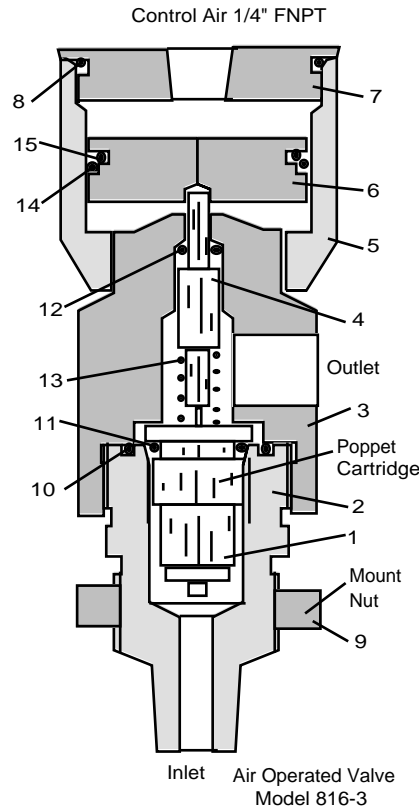

NOTES

1. Use Cristo lub MCG 121 or 111 or equivalent. grease on O rings . Fully pack 12, 14, & 15 .
- 2 & 3 delete
4. Technical bulletin - 818
5. Cut through one side of O ring item 15 to insure it acts only as an expander and not as a seal.
6. TO AVOID PREMATURE FAILURE OF STEM ITEM 4 AN ORIFICE IS REQUIRED AT THE CONTROL AIR PORT. A .047" (#56 DRILL) ORIFICE IS ADEQUATE HOWEVER A .025" ORIFICE INSURES MAXIMUM LIVE. IT IS IMPORTANT TO PLACE THE ORIFICE DIRECTLY ON THE 816 CONTROL PORT TO AVOID EXCESSIVE DEAD VOLUME. The .025" orifice causes about a 1/2 second delay between release of control pressure and venting of high pressure.
7. Revisions/history - 030224 added note 6.
8. Tighten cap (3) to body (2) with 180 to 300 inch-pounds of torque.

ASSEMBLY 832 Poppet cartridge

ITEM	QTY	PART NO.	DESCRIPTION
1	1	808	retainer nut
2	1	806	poppet housing
3	1	809	sleeve
4	1	807	seat
5	1	741	poppet
6	1	871-6	2-014 O ring
7	1	871-7	2-009 O ring
8	1	871-8	spring
9	1	871-9	filter

NOTES

1. It is recommended that replacement cartridges are stocked for in-field repairs and defective cartridges returned to the factory for service. In an emergency the cartridge can be serviced by following the above drawing and parts list. Extreme cleanliness is required.

